



# UMT MARINE

QUALITY IN EVERYTHING WE DO

*ECO600*

*PRODUCT SHEET*

**RATED CAPACITY**

ECO600: 600 lbs / 272 kg

The *ECO600* is an affordable entry level davit simply designed for an easy one person operation. The *ECO600* is offered in two lengths. The davit is easy to maintain and is covered by UMT Service & Support.

**SYSTEM WEIGHT**

ECO600: 98 lbs / 44 kg

**RECOMMENDED VESSEL**

ECO600: 40ft+ / 12m+

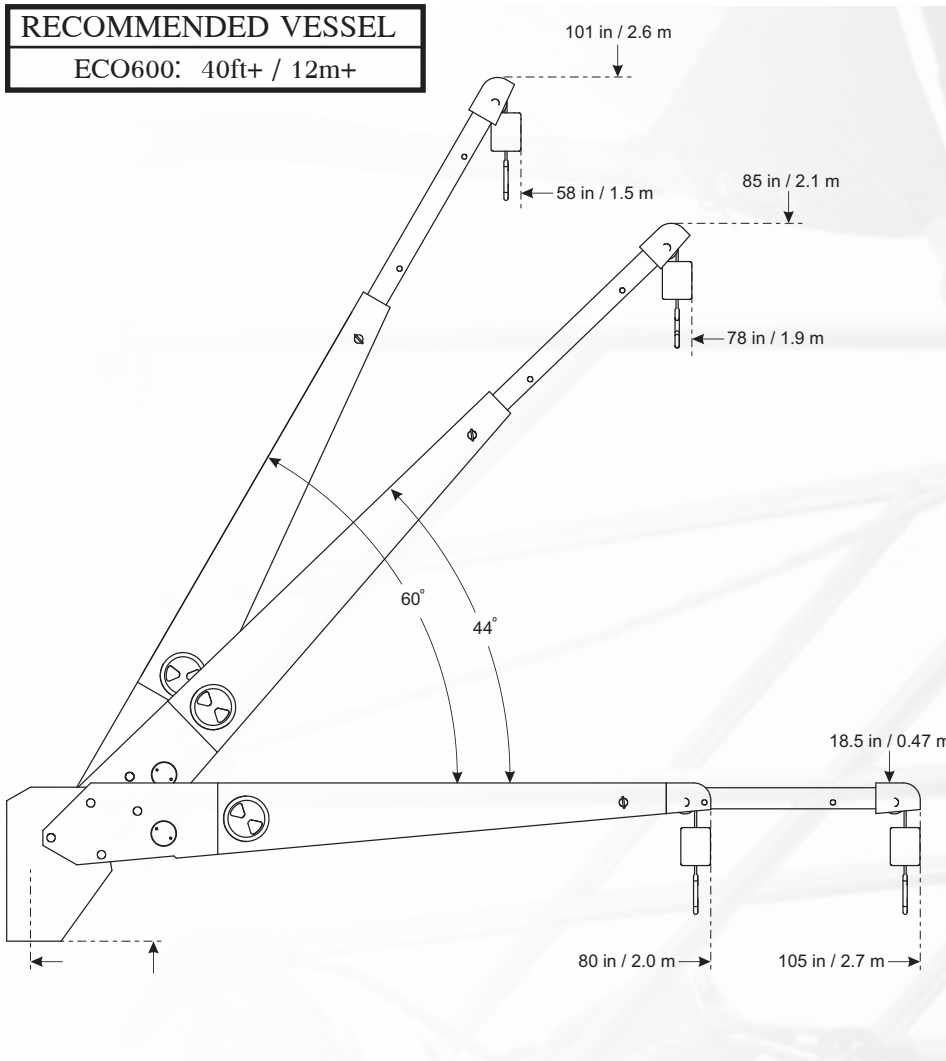

**SYSTEM SPECIFICATION**

**LIFT**

Manual (Air-Assist)

**ROTATION**

360° Manual

**EXTENSION**

Manual

**CABLE SYSTEM**

Electric Winch 110V AC  
3/16" Stainless Steel Cable  
Cable Length: 20ft / 6m

**RETRACTED**

Short Boom: 6.5ft / 1.9m  
Long Boom: 8ft / 2.4m

**REACH**

Short Boom: 9ft / 2.7m  
Long Boom: 12ft / 3.6m

**OPTIONS**

Base or Standpipe Mount  
12 / 24V DC Power  
Custom Colors

**WARRANTY**

5 Year Limited Structural  
2 Year Limited Electrical  
1 Year Limited Paint & Finish